

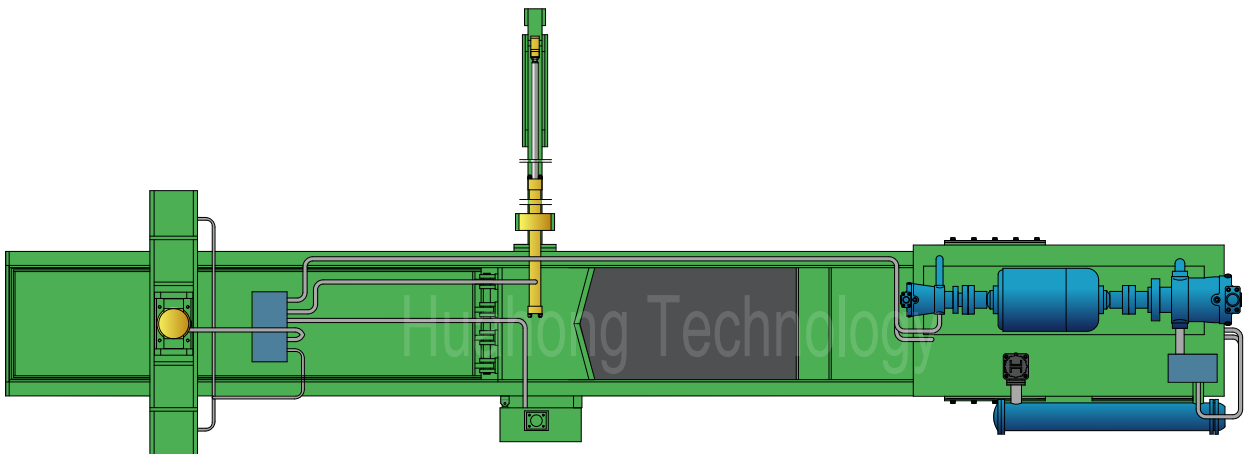

HPA150B

Plan View

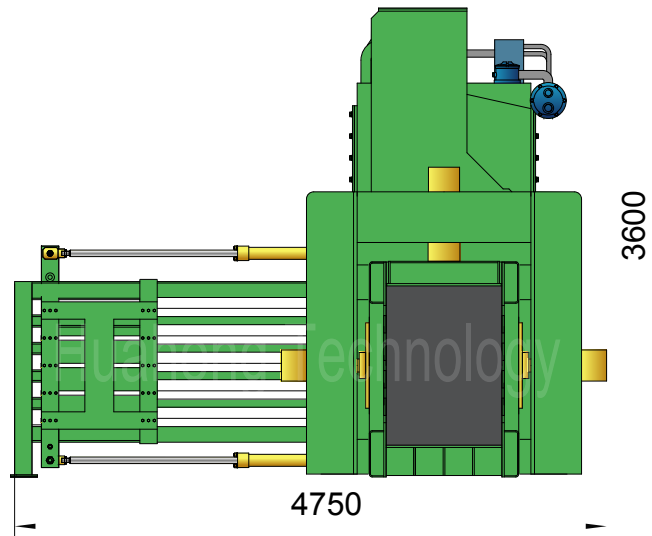

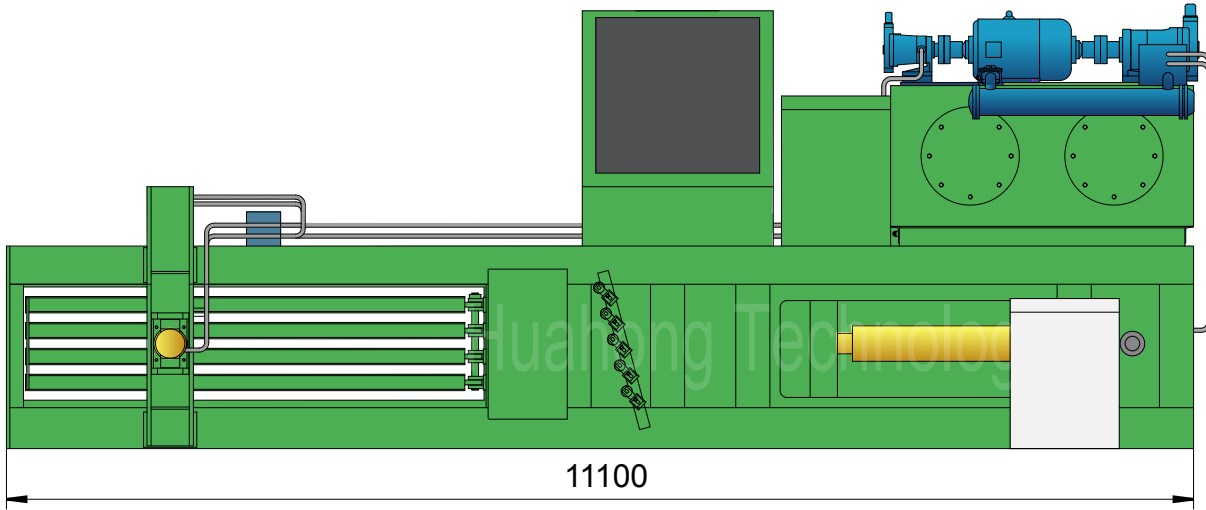

HPA150B

Technical parameters

Horizontal Baler (Automatic Belting)

Model: HPA150B

Power System (Main Motor, 2 sets)

Type:	Y280S-6
Rated Power:	45 kW (/set)
Rated Speed:	980 rpm
Power Spec:	3PH, 50 / 60Hz

System Parameters

Main Pressure Cyl. Force:	150 Ton
Necking Cyl. Force:	3×80 Ton
Wire Pushing Cyl. Force:	8 Ton
Wire Cutting Cyl. Force:	8 Ton
Hydraulic System Pressure:	25 MPa

Hydraulic System (Pump, 3 sets)

Pump #1, #2:	250YCY14-1B
Rated Displacement:	250 ml/r (/set)
Max Operating Pressure:	31.5 MPa

Standard Configuration

NOK (JAPAN) Seal Packings for Cylinders;
V-shaped Cutting Blades; Wire Frame; Oil Cooler;
Conveyor Width 1600mm, Powered by 7.5kW Motor.

Pump #3:	40YCY14-1B
Rated Displacement:	40 ml/r
Max Operating Pressure:	31.5 MPa

Optional Configuration

Oil Heater; Magnetic Oil Filter;
Siemens PLC S7-300 for Long Distance Data Transmission;
Rexroth Pumps; Siemens Electrical Elements;
Diesel / Diesel Generator for Power.

Operation System

Mitsubishi / Siemens PLC & Touch Screen.

General Description

Main Machine Size (L×W×H):	11100×4750×3600 mm
Feeding Opening (L×W):	2200×1100 mm
Bale Size (W×H):	1100×1250 mm
Bale Weight (Cardboard):	830-1400 kg
Production Rate (Cardboard):	8.3-12.6 tons/hr
Strapping:	Tempered Iron Wire, φ3.2/3.6mm, 5 Lines, Automatic Strapping.
Shipping Weight:	Approx. 26.5 + 7 tons
Loading (Standard Containers):	2×40'GP

Hydraulic Oil Brand

Oil Tank Volume: 3000 ltr

ISO VG	China	U.S.		Britain	France
	GB11118.1	CALTEX CO.	MOBIL	SHELL	ELF CO.
HM 46	46 #	Rando HD46	D.T.E46	Tellus 46	Elfolna 46
HM 68	68 #	Rando HD68	D.T.E68	Tellus 68	Elfolna 68

Above information are indicative not engaging. Rights reserved for change if necessary.